

# WTO

## QuickFlex®

高效能及高精度的全新快換系統

最小的投資，最大的擴充性



快換刀把  
產品目錄

# QuickFlex®

最小的投資，最大的擴充性

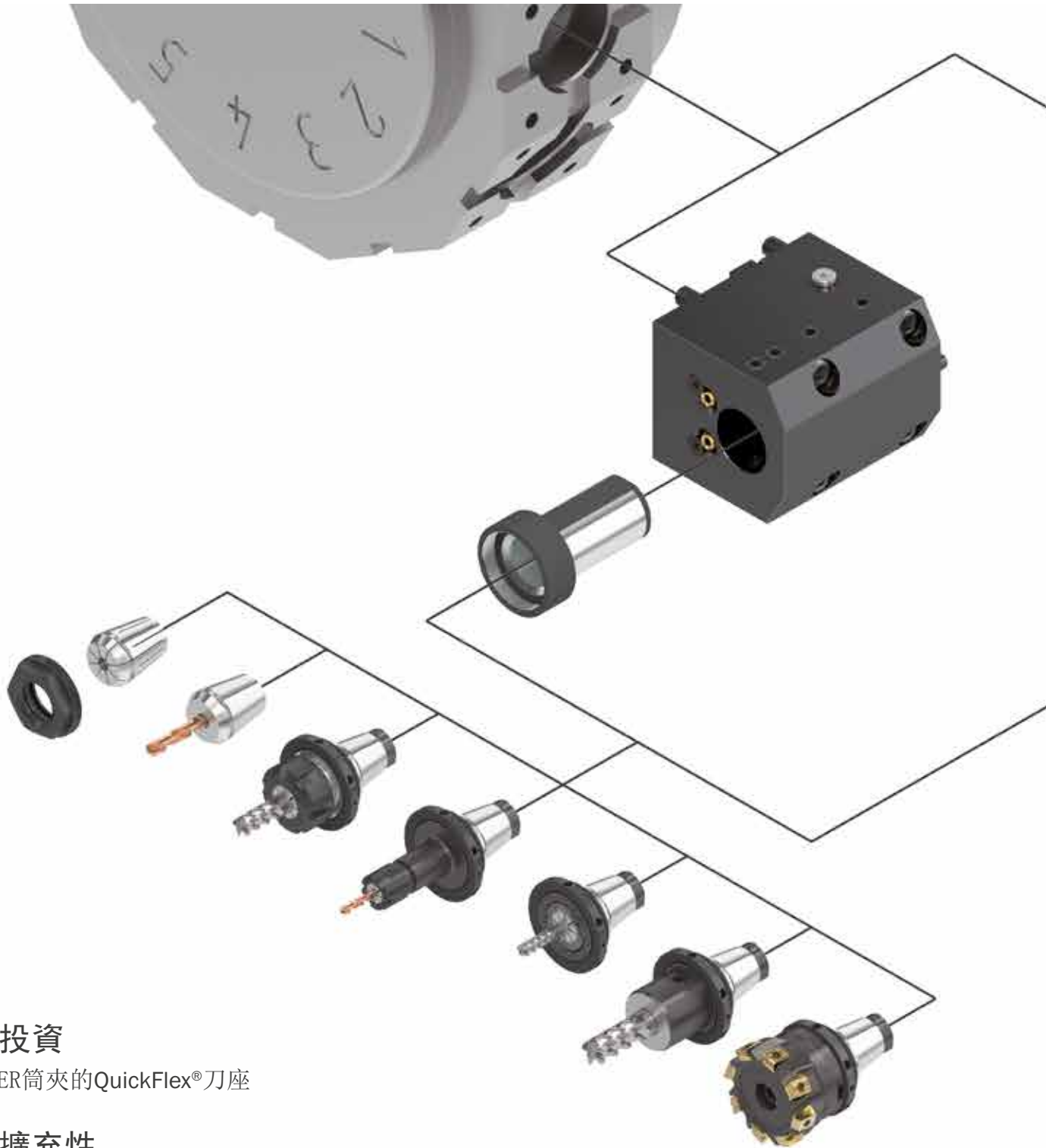

## 最小的投資

使用標準ER筒夾的QuickFlex®刀座

## 最大的擴充性

根據生產需要，購買QuickFlex®刀把，經由快換功能來降低刀具更換時間。

QuickFlex® 快換刀把及刀座種類繁多，適用於配有動力刀盤之車削中心。

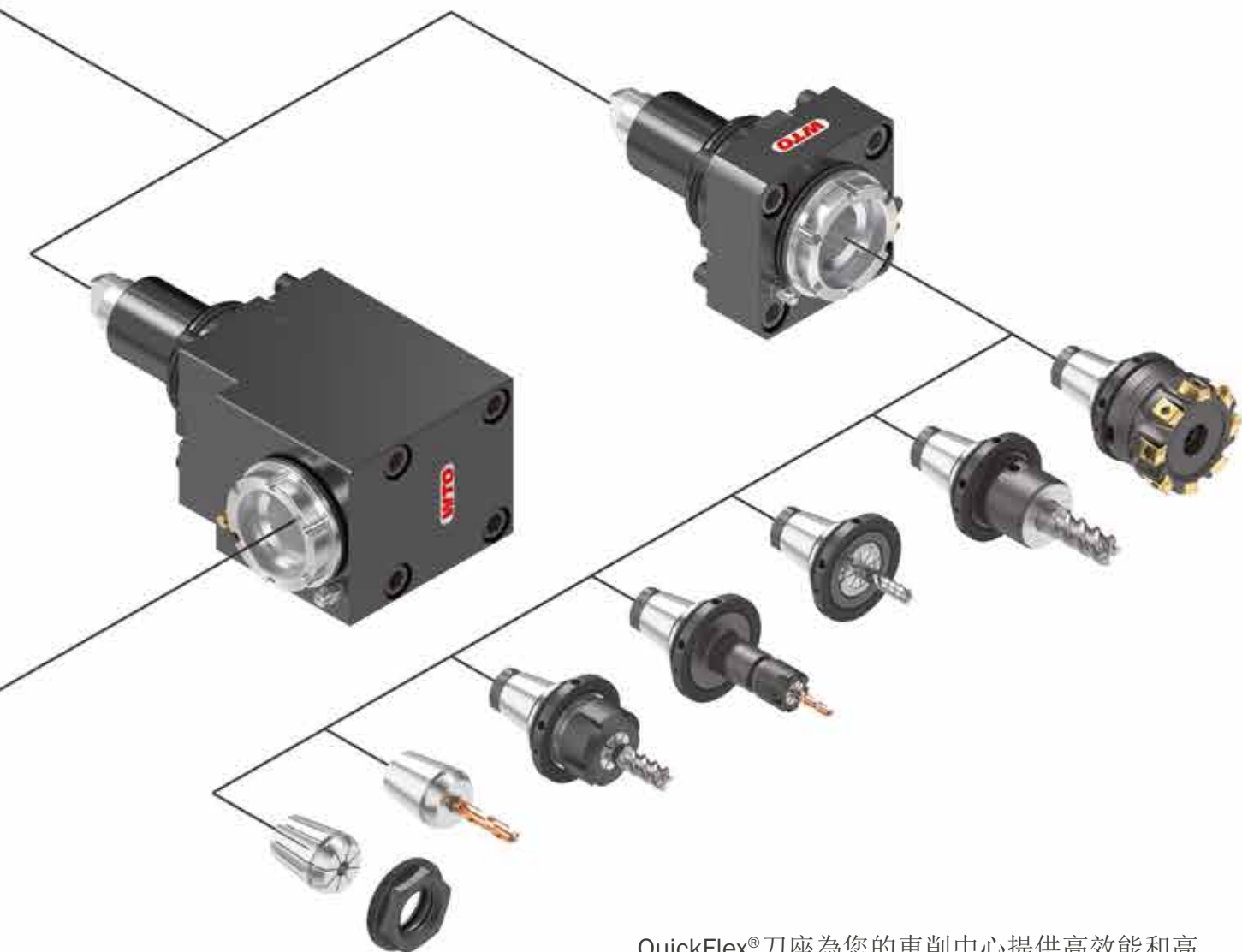

QuickFlex®刀座為您的車削中心提供高效能和高精密度。



# QuickFlex®

完美的結合：  
ER筒夾與快換刀把合而為一的雙功能刀座



- 1 - 刀座
- 2 - QuickFlex® 夾頭
- 3 - 筒夾
- 4 - 鎖緊螺帽
- 5 - QuickFlex® 快換刀把
- 6 - 單手固定板手(註冊專利)
- 7 - 鎖緊螺帽及QuickFlex®  
快換刀把共用螺紋
- 8 - 短斜錐介面提供QuickFlex®  
快換刀把之徑向定位及軸向支撐
- 9 - ER 筒夾斜錐介面
- 10 - 三角凹槽提供QuickFlex®  
快換刀把之扭力傳遞
- 11 - 徑向支撐提供QuickFlex®  
快換刀把之高徑向撓曲剛性

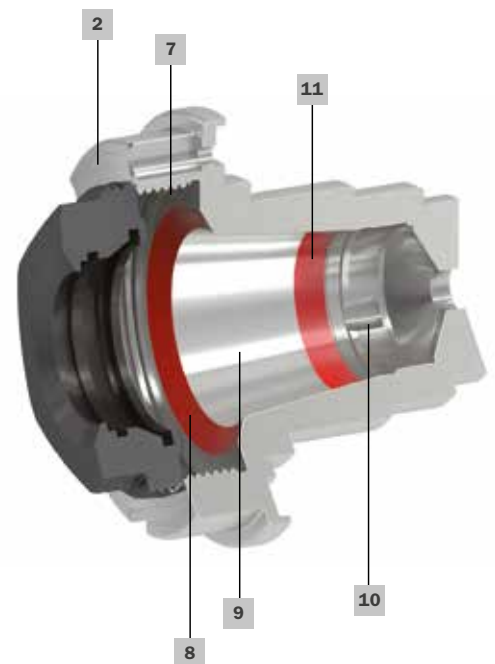

兩個獨立斜錐介面，確保長期使用精度

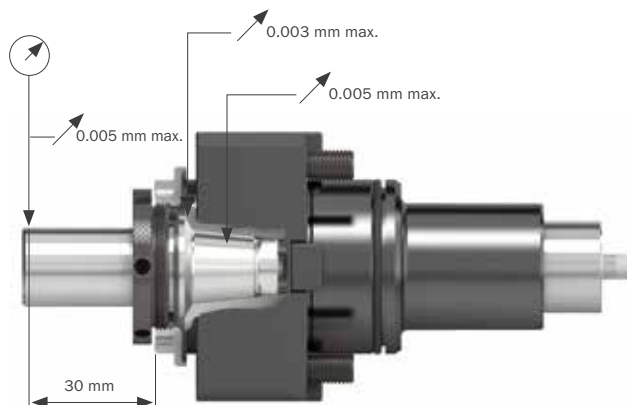
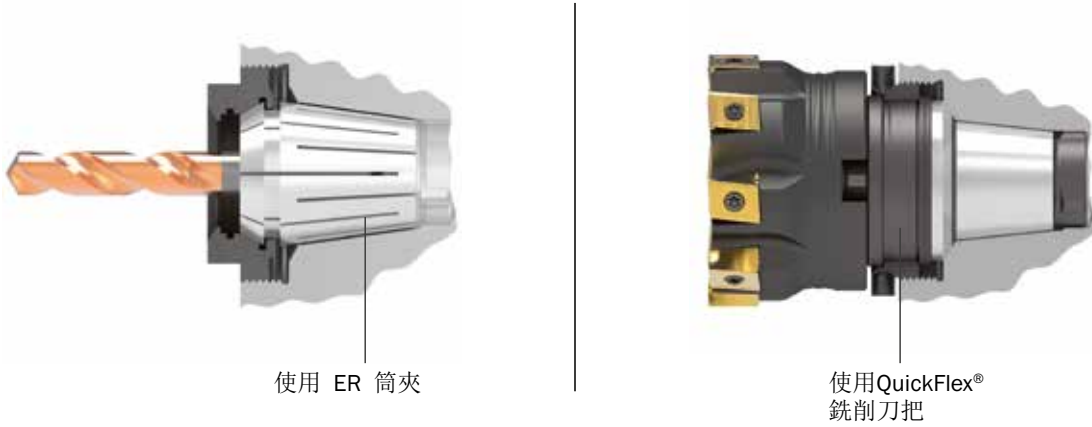

使用專利之單手固定板手，在更換刀具時，  
動作更為快速及安全

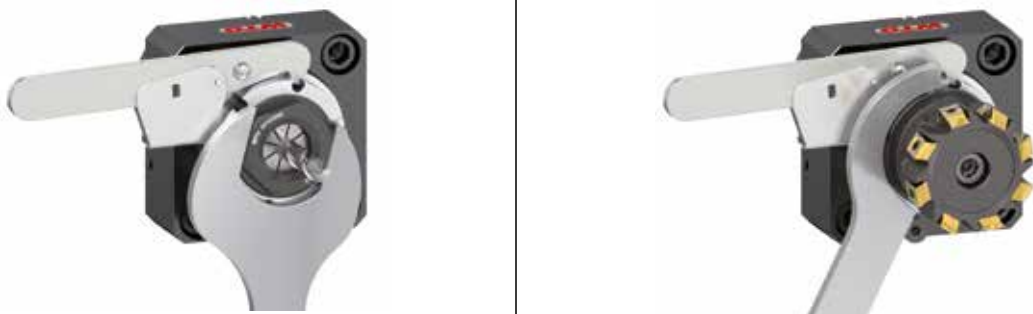

## 直柄刀把

直柄附側固平面

可於搪刀固定刀座上彈性應用QuickFlex® 刀把

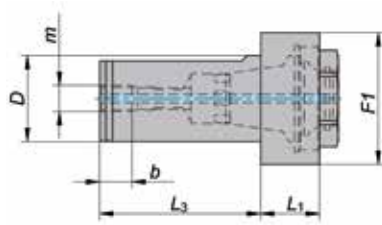

尺寸	訂購編號	D	d min.	d max.	L <sub>3</sub>	F <sub>1</sub>	L <sub>1</sub>	m	b	
ER-25QF	330025032	32	1	16	60	49	22	G $\frac{1}{8}$ "	12	107525020
ER-32QF	330032040	40	2	20	70	58	22	G $\frac{1}{4}$ "	15	107532020
ER-40QF	330040050	50	3	26	80	71	22	G $\frac{3}{8}$ "	19	107540020

尺寸為  
mm

尺寸	訂購編號	D	d min.	d max.	L <sub>3</sub>	F <sub>1</sub>	L <sub>1</sub>	m	b	
ER-25QF	330025125	1.250	0.039	0.630	2.362	1.929	0.866	G $\frac{1}{8}$ "	0.472	107525020
ER-32QF	330032150	1.500	0.079	0.787	2.756	2.283	0.866	G $\frac{1}{4}$ "	0.591	107532020
ER-40QF	330040200	2.000	0.118	1.024	3.149	2.795	0.866	G $\frac{3}{8}$ "	0.748	107540020

尺寸為  
英寸

## 基本組合



尺寸	訂購編號	 單手固定扳手	 QuickFlex® 刀把用鎖固扳手	 側固刀把	 銑刀刀把	 筒夾夾頭刀把	 扳手	尺寸為 mm
ER-20QF	007020000	107720000	107520020	Ø 12 mm	Ø 16 mm	ER 20	107520000	
ER-25QF <sup>1)</sup>	007025000	107725000	107525020	Ø 16 mm	Ø 16 mm	ER 25	107525000	
ER-25QF <sup>1)</sup>	007025010	107725010	107525020	Ø 16 mm	Ø 16 mm	ER 25	107525000	
ER-32QF	007032000	107732000	107532020	Ø 20 mm	Ø 22 mm	ER 32	107532000	
ER-40QF	007040000	107740000	107540020	Ø 25 mm	Ø 27 mm	ER 40	107540000	
ER-50QF	007050000	107750000	107550020	Ø 25 mm	Ø 27 mm	ER 40	107540000	

<sup>1)</sup> 訂購前，請先確認對應的刀座型式



尺寸	訂購編號	 單手固定扳手	 QuickFlex® 刀把用鎖固扳手	 側固刀把	 銑刀刀把	 筒夾夾頭刀把	 扳手	尺寸為 英寸
ER-20QF	007020001	107720000	107520020	Ø 0.5 inch	Ø 0.750 inch	ER 20	107520000	
ER-25QF <sup>1)</sup>	007025001	107725000	107525020	Ø 0.625 inch	Ø 0.750 inch	ER 25	107525000	
ER-25QF <sup>1)</sup>	007025011	107725010	107525020	Ø 0.625 inch	Ø 0.750 inch	ER 25	107525000	
ER-32QF	007032001	107732000	107532020	Ø 0.750 inch	Ø 0.750 inch	ER 32	107532000	
ER-40QF	007040001	107740000	107540020	Ø 1 inch	Ø 1 inch	ER 40	107540000	
ER-50QF	007050001	107750000	107550020	Ø 1 inch	Ø 1 inch	ER 40	107540000	

<sup>1)</sup> 訂購前，請先確認對應的刀座型式

## 筒夾夾頭刀把

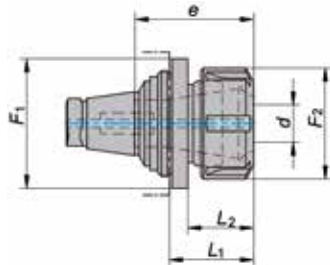
DIN 6499, ISO 15488



尺寸	訂購編號	F1	d min.	d max.	F2	e	L2	L1	筒夾 尺寸		
ER-20QF	320020010	36	0.5	10	28	40	23	29	ER 16	200016000	107516000
	320020013	36	1	13	34	45	24	30	ER 20	200020000	107520000
ER-25QF	320025010	49	0.5	10	28	40	23	30	ER 16	200016000	107516000
	320025013	49	1	13	34	45	24	31	ER 20	200020000	107520000
	320025016	49	1	16	42	48	25	32	ER 25	200025000	107525000
ER-32QF	320032013	58	1	13	34	45	24	31	ER 20	200020000	107520000
	320032016	58	1	16	42	48	25	32	ER 25	200025000	107525000
	320032020	58	2	20	50	50	28	35	ER 32	200032000	107532000
ER-40QF	320040016	71	1	16	42	48	25	33	ER 25	200025000	107525000
	320040020	71	2	20	50	50	28	36	ER 32	200032000	107532000
	320040026	71	3	26	63	55	35	43	ER 40	200040000	107540000
ER-50QF	320050020	82	2	20	50	50	28	37	ER 32	200032000	107532000
	320050026	82	3	26	63	55	35	44	ER 40	200040000	107540000

尺寸, mm



## 筒夾夾頭刀把 - 短型

DIN 6499, ISO 15488

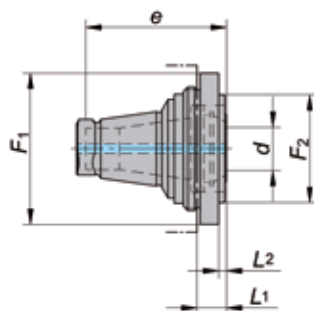



尺寸	訂購編號	F <sub>1</sub>	d min.	d max.	F <sub>2</sub>	e	L <sub>2</sub>	L <sub>1</sub>	筒夾 尺寸			
ER-20QF	320020007-09	36	0.5	7	-	36	-	6	ER 11	200111001	107511101	-
ER-25QF	320025010-07	49	0.5	10	-	40	-	7	ER 16	200116001	107516101	-
	320025013-09	49	1	13	35	45	2	9	ER 20	200120001	107520101	-
ER-32QF	320032013-07	58	1	13	-	45	-	7	ER 20	200120001	107520101	-
	320032016-07	58	1	16	-	48	-	7	ER 25	200125001	107525101	107525104
ER-40QF	320040016-08	71	1	16	-	48	-	8	ER 25	200125001	107525101	107525104
	320040020-08	71	2	20	-	50	-	8	ER 32	200132001	107532101	107532104
ER-50QF	320050020-09	82	2	20	-	50	-	9	ER 32	200132001	107532101	107532104
	320050026-09	82	3	26	-	56	-	9	ER 40	200140001	107540101	107540104

尺寸, mm

## 筒夾夾頭刀把 - 加長型

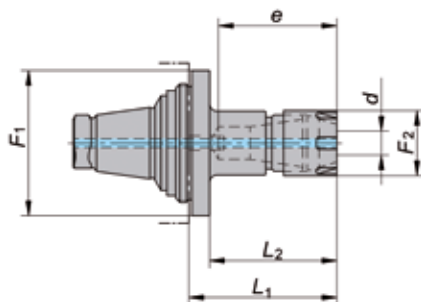
DIN 6499, ISO 15488





尺寸	訂購編號	F <sub>1</sub>	d min.	d max.	F <sub>2</sub>	e	L <sub>2</sub>	L <sub>1</sub>	筒夾 尺寸		
ER-20QF	320020007-40	36	0.5	7	16	36	34	40	ER 11	200511000	107511005
ER-25QF	320025007-40	49	0.5	7	16	36	33	40	ER 11	200511000	107511005
	320025010-50	49	0.5	10	22	40	43	50	ER 16	200516000	107516005
ER-32QF	320032007-50	58	0.5	7	16	36	43	50	ER 11	200511000	107511005
	320032010-60	58	0.5	10	22	40	53	60	ER 16	200516000	107516005
ER-40QF	320040010-60	71	0.5	10	22	40	52	60	ER 16	200516000	107516005
	320040016-60	71	1	16	35	48	52	60	ER 25	200525000	107525005

尺寸, mm

## 側固刀把

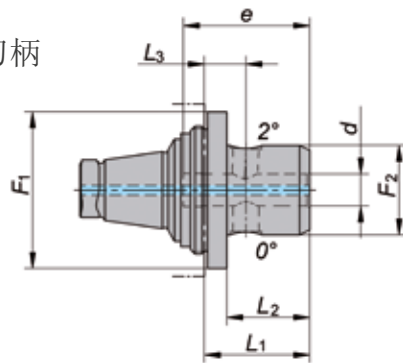
適用於DIN 6535-HB 及 -HE 刀柄





尺寸	訂購編號	F1	d	F2	L3	e	L2	L1		
ER-20QF	320120006	36	6	19	10	36	22	28	12882	26071
	320120008	36	8	21	11	36	23	29	12927	26072
	320120010	36	10	28	12	40	26	32	12992	26073
	320120012	36	12	34	14.5	45	31	37	13061	26074
	320120014	36	14	36	15.5	45	32	38	13061	26074
	320120016	36	16	38	18	49	36	42	30944	26075
ER-25QF	320125006	49	6	19	11	36	22	29	12882	26071
	320125008	49	8	21	12	36	23	30	12927	26072
	320125010	49	10	28	13	40	26	33	12992	26073
	320125012	49	12	34	13.5	45	29	36	13061	26074
	320125014	49	14	36	13.5	45	29	36	13061	26074
	320125016	49	16	38	16	49	33	40	30944	26075
	320125018	49	18	40	16	49	33	40	30944	26075
	320125020	49	20	45	18	51	36	43	106290	26076
ER-32QF	320132006	58	6	19	11	36	22	29	12882	26071
	320132008	58	8	21	12	36	23	30	12927	26072
	320132010	58	10	28	13	40	26	33	12992	26073
	320132012	58	12	34	13.5	45	29	36	13061	26074
	320132014	58	14	36	13.5	45	29	36	13061	26074
	320132016	58	16	38	16	49	33	40	30944	26075
	320132018	58	18	40	16	49	33	40	30944	26075
	320132020	58	20	45	17	51	35	42	106290	26076
320132025	58	25	51	22	57	39	46	13128	26076	
ER-40QF	320140006	71	6	19	12	36	22	30	12882	26071
	320140008	71	8	21	13	36	23	31	12927	26072
	320140010	71	10	28	14	40	26	34	12992	26073
	320140012	71	12	34	14.5	45	29	37	13061	26074
	320140014	71	14	36	14.5	45	29	37	13061	26074
	320140016	71	16	38	17	49	33	41	30944	26075
	320140018	71	18	40	17	49	33	41	30944	26075
	320140020	71	20	45	18	51	35	43	106290	26076
320140025	71	25	51	18	57	34	42	13128	26076	
ER-50QF	320150006	82	6	19	13	36	22	31	12882	26071
	320150008	82	8	21	14	36	23	32	12927	26072
	320150010	82	10	28	15	40	26	35	12992	26073
	320150012	82	12	34	15.5	45	29	38	13061	26074
	320150014	82	14	36	15.5	45	29	38	13061	26074
	320150016	82	16	38	18	49	33	42	30944	26075
	320150018	82	18	40	18	49	33	42	30944	26075
	320150020	82	20	45	19	51	35	44	106290	26076
320150025	82	25	51	19	57	34	43	13128	26076	
320150032	82	32	72	23	61	38	47	71255	26077	

尺寸為  
mm

## 側固刀把

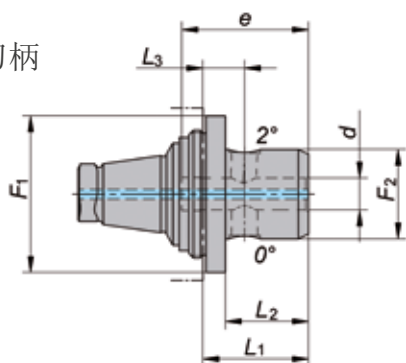
適用於DIN 6535-HB 及 -HE 刀柄







尺寸	訂購編號	F1	d	F2	L3	e	L2	L1		
ER-20QF	3201200250	1.417	0.25	0.748	0.413	1.417	0.886	1.122	84754	85127
	3201200312	1.417	0.312	0.826	0.433	1.417	0.905	1.141	84754	85127
	3201200375	1.417	0.375	1.102	0.511	1.574	1.062	1.299	84755	84845
	3201200500	1.417	0.5	1.338	0.570	1.771	1.220	1.456	84756	84846
	3201200625	1.417	0.625	1.614	0.708	1.889	1.417	1.653	84757	84847
ER-25QF	3201250250	1.929	0.25	0.748	0.472	1.417	0.905	1.181	84754	85127
	3201250312	1.929	0.312	0.826	0.472	1.417	0.905	1.181	84754	85127
	3201250375	1.929	0.375	1.102	0.511	1.574	1.023	1.299	84755	84845
	3201250500	1.929	0.5	1.338	0.531	1.771	1.141	1.417	84756	84846
	3201250625	1.929	0.625	1.614	0.629	1.889	1.299	1.574	84757	84847
ER-32QF	3201320250	2.283	0.25	0.748	0.472	1.417	0.905	1.181	84754	85127
	3201320312	2.283	0.312	0.826	0.472	1.417	0.905	1.181	84754	85127
	3201320375	2.283	0.375	1.102	0.511	1.574	1.023	1.299	84755	84845
	3201320500	2.283	0.5	1.338	0.570	1.771	1.181	1.456	84756	84846
	3201320625	2.283	0.625	1.614	0.629	1.889	1.299	1.574	84757	84847
ER-40QF	3201400250	2.795	0.25	0.748	0.511	1.417	0.905	1.220	84754	85127
	3201400312	2.795	0.312	0.826	0.511	1.417	0.905	1.220	84754	85127
	3201400375	2.795	0.375	1.102	0.590	1.574	1.062	1.378	84755	84845
	3201400500	2.795	0.5	1.338	0.610	1.771	1.181	1.496	84756	84846
	3201400625	2.795	0.625	1.614	0.669	1.889	1.299	1.614	84757	84847
ER-50QF	3201500250	3.228	0.25	0.748	0.551	1.417	0.905	1.259	84754	85127
	3201500312	3.228	0.312	0.826	0.551	1.417	0.905	1.259	84754	85127
	3201500375	3.228	0.375	1.102	0.629	1.574	1.062	1.417	84755	84845
	3201500500	3.228	0.5	1.338	0.649	1.771	1.181	1.535	84756	84846
	3201500625	3.228	0.625	1.614	0.708	1.889	1.299	1.653	84757	84847
	3201500750	3.228	0.75	1.771	0.748	2.007	1.377	1.732	84758	26076
	3201500875	3.228	0.875	1.968	0.748	1.968	1.377	1.732	84758	26076
	3201501000	3.228	1	2.362	0.787	2.244	1.377	1.732	84759	84848
	3201501250	3.228	1.25	2.637	0.905	2.401	1.496	1.850	84759	84848

尺寸為  
英寸

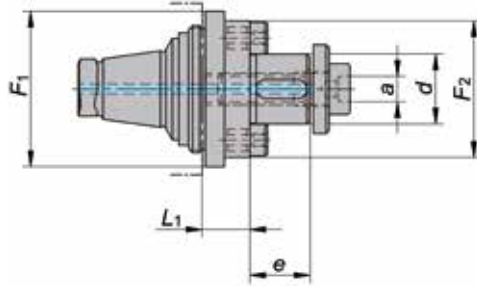
## 銑刀刀把

適用於面銑刀及側銑刀



尺寸	訂購編號	F1	d	F2	e	L1	a				
ER-20QF	320220016	36	16	35	17	12	6	84130	84903	26075	
ER-25QF	320225016	49	16	35	17	8	6	84130	84903	26075	
	320225022	49	22	43	19	15	8	84131	84904	26076	
	320225027	49	27	50	21	15	10	84132	84905	26077	
ER-32QF	320232016	58	16	35	17	8	6	84130	84903	26075	
	320232022	58	22	43	19	8	8	84131	84904	26076	
	320232027	58	27	50	21	15	10	84132	84905	26077	
ER-40QF	320240022	71	22	43	19	9	8	84131	84904	26076	
	320240027	71	27	53	21	9	10	84132	84905	26077	
	320240032	71	32	63	24	20	14	84133	84906	26078	
ER-50QF	320250022	82	22	43	19	10	8	84131	84904	26076	
	320250027	82	27	53	21	10	10	84132	84905	26077	
	320250032	82	32	61	24	10	14	84133	84906	26078	

尺寸為  
mm

通用設計：  
鍵及驅動塊均可  
拆除

所有刀把均附標準螺拴，無中心出水油孔。

選配螺拴，有中心出水油孔。

d		
16	84841	26075
22	84842	26076
27	84843	26077
32	84844	26078

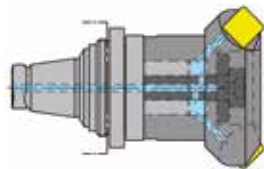

尺寸, mm

## 銑刀刀把

適用於面銑刀及側銑刀

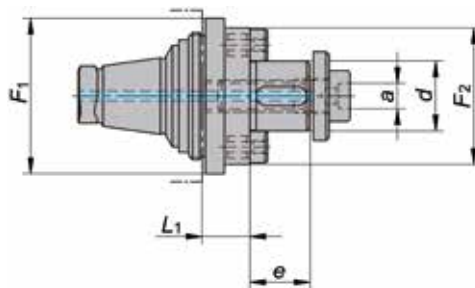

尺寸	訂購編號	F <sub>1</sub>	d	F <sub>2</sub>	e	L <sub>1</sub>	a			
ER-20QF	3202200750	1.417	0.75	1.574	0.708	0.629	0.25	84809	84813	84847
ER-25QF	3202250750	1.929	0.75	1.574	0.708	0.590	0.25	84809	84813	84847
	3202251000	1.929	1	1.968	0.708	0.590	0.313	84810	84814	26076
ER-32QF	3202320750	2.283	0.75	1.692	0.708	0.314	0.25	84809	84813	84847
	3202321000	2.283	1	1.968	0.708	0.590	0.313	84810	84814	26076
	3202321250	2.283	1.25	2.480	0.708	0.807	0.313	84811	84815	26076
ER-40QF	3202401000	2.795	1	2.086	0.708	0.354	0.313	84810	84814	26076
	3202401250	2.795	1.25	2.480	0.708	0.787	0.313	84811	84815	26076
ER-50QF	3202501000	3.228	1	1.968	0.708	0.393	0.313	84810	84814	26076
	3202501250	3.228	1.25	2.480	0.708	0.472	0.313	84811	84815	26076

尺寸為  
英寸

通用設計：  
鍵及驅動塊均可  
拆除

所有刀把均附標準螺拴，無中心出水油孔。

選配螺拴，有中心出水油孔。

d		
0.75	84849	26076
1	84850	84848
1.25	84851	85128

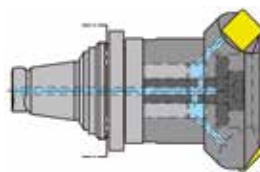

尺寸, mm

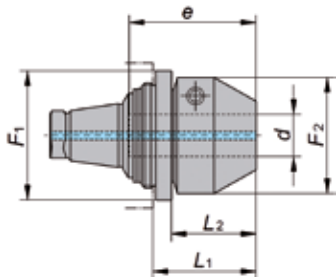

## 高精度油壓夾頭

適用於全圓柄刀具



尺寸	訂購編號	F1	d	F2	e	L2	L1		Nm		
ER-25QF	320425016	49	16	44	48	32	39	3	5	STW-T-W3-A 可換頭六角板手 (含六角頭)	六角頭 118077
ER-32QF	320432020	58	20	52	53	31	38	4	10	STW-T-W4-A	118078
ER-40QF	320440025	71	25	59	58	31	39	4	10	STW-T-W4-A	118078

請注意最大鎖緊扭力 (Nm)! 尺寸, mm

## 油壓夾頭用變徑筒夾

開槽型

密封型，中心出水用



d	D16	D20	D25
2	244016002	244020002	-
3	244016003	244020003	244025003
4	244016004	244020004	244025004
5	244016005	244020005	244025005
6	244016006	244020006	244025006
7	244016007	244020007	244025007
8	244016008	244020008	244025008
9	244016009	244020009	244025009
10	244016010	244020010	244025010
12	244016012	244020012	244025012
14	244016014	244020014	244025014
16	-	244020016	244025016
18	-	-	244025018
20	-	-	244025020
22	-	-	244025022

尺寸, mm

d	D16	D20	D25
2	-	-	-
3	244116003	244120003	244125003
4	244116004	244120004	244125004
5	244116005	244120005	244125005
6	244116006	244120006	244125006
7	244116007	244120007	244125007
8	244116008	244120008	244125008
9	244116009	244120009	244125009
10	244116010	244120010	244125010
12	244116012	244120012	244125012
14	244116014	244120014	244125014
16	-	244120016	244125016
18	-	-	244125018
20	-	-	244125020
22	-	-	244125022

尺寸, mm

## powRgrip® 筒夾刀把

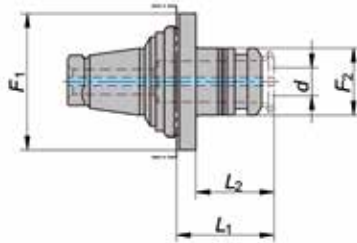

尺寸	訂購編號	F <sub>1</sub>	d min.	d max.	F <sub>2</sub>	L <sub>1</sub>	L <sub>2</sub>	筒夾 尺寸
ER-20QF	325220P15	36	3	10	24	34	28	PGST 15
ER-25QF	325225P15	49	3	10	24	35	28	PGST 15
ER-32QF	325232P25	58	3	20	40	47	40	PGST 25
ER-40QF	325240P25	71	3	20	40	48	40	PGST 25

尺寸, mm

## powRgrip® PGST 筒夾

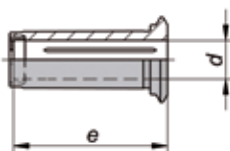

d	e	PGST	WTO 訂購編號	REGO-FIX 訂購編號
3	28	PGST 15	244P15003	1715.03006
4	28	PGST 15	244P15004	1715.04006
6	36	PGST 15	244P15006	1715.06006
8	36	PGST 15	244P15008	1715.08006
10	40	PGST 15	244P15010	1715.10006

尺寸為  
mm

3	28	PGST 25	244P25003	1725.03006
4	28	PGST 25	244P25004	1725.04006
6	36	PGST 25	244P25006	1725.06006
8	36	PGST 25	244P25008	1725.08006
10	40	PGST 25	244P25010	1725.10006
12	45	PGST 25	244P25012	1725.12006
16	48	PGST 25	244P25016	1725.16006
20	48	PGST 25	244P25020	1725.20006

d	e	PGST	WTO 訂購編號	REGO-FIX 訂購編號
1/8"	28	PGST 15	244P150013	1715.03186
3/16"	28	PGST 15	244P150019	1715.04766
1/4"	36	PGST 15	244P150025	1715.06356
5/16"	36	PGST 15	244P150031	1715.07946
3/8"	40	PGST 15	244P150038	1715.09526



尺寸為  
英寸

1/8"	28	PGST 25	244P250013	1725.03186
3/16"	28	PGST 25	244P250019	1725.04766
1/4"	36	PGST 25	244P250025	1725.06356
5/16"	36	PGST 25	244P250031	1725.07946
3/8"	40	PGST 25	244P250038	1725.09526
1/2"	45	PGST 25	244P250050	1725.12706
5/8"	48	PGST 25	244P250063	1725.15886
3/4"	48	PGST 25	244P250075	1725.19056

## MPHC 浮動筒夾刀把

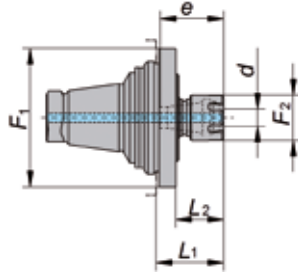
DIN 6499, ISO 15488



尺寸	訂購編號	F <sub>1</sub>	d min.	d max.	F <sub>2</sub>	e	L <sub>2</sub>	L <sub>1</sub>	筒夾 尺寸		
ER-25QF	325325M11	49	0.5	7	16	22.5	17	24	ER 11	200511000	107511005
ER-32QF	325332M16	58	0.5	10	22	33	33	26	ER 16	200516000	107516005

尺寸, mm

軸心不準時加工問題：



孔徑變大



錐孔，入口孔徑變大



錐孔，出口孔徑變大



絞刀排屑不良折斷



孔面粗度不佳



孔面呈現顫紋





軸心偏移

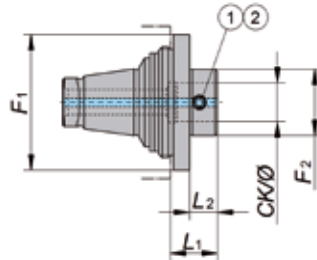

## BIG KAISER 轉接刀把

配合CBK1 到 CBK4



尺寸	訂購編號	CK/Ø	F1	F2	L1	L2		
ER-25QF	325125CK1	CKB1/11	49	19	15.5	8.5	103828	26079
	325125CK3	CKB3/18	49	31	19.5	12.5	72733	26072
ER-32QF	325132CK1	CKB1/11	58	19	15.5	8.5	103828	26079
	325132CK3	CKB3/18	58	31	19.5	12.5	72733	26072
ER-40QF	325140CK2	CKB2/14	71	24	18	10	69040	26071
	325140CK4	CKB4/22	71	39	23	15	67821	26073
ER-50QF	325150CK2	CKB2/14	82	24	19	10	69040	26071
	325150CK4	CKB4/22	82	39	24	15	67821	26073

尺寸, mm

## 刀具組合及加工範圍

詳細刀具及配件規格請參閱 BIG KAISER 目錄

### 精密搪刀頭 EWN, 112 系列, Ø 0.4 - 24.8 mm

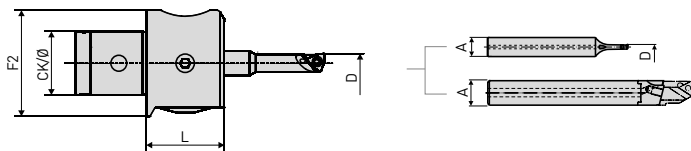

搪刀頭	CK/Ø	D	A	L	F2
EWN 04-15	CK3/18	0.4-15.5	7	22	31
EWN 04-22	CK4/22	0.4-24.8	10	28	39

請參閱 BIG KAISER 目錄 B51-55. 尺寸, mm

### 精密搪刀頭 EWN, 310 系列, Ø 20 - 74 mm

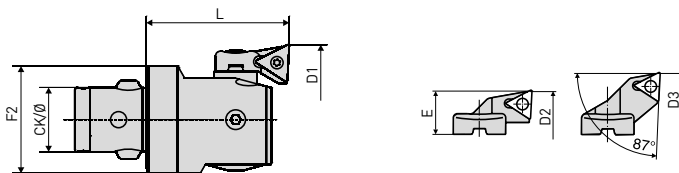

搪刀頭	CK/Ø	D1	D2	D3	L	F2
EWN 20	CKB1/11	20-26	25-31	30-36	32.5	19
EWN 25	CKB2/14	25-33	32-40	39-47	35.5	24
EWN 32	CKB3/18	32-42	41-51	50-60	40	31
EWN 41	CKB4/22	41-54	50-63	61-74	47	39

請參閱 BIG KAISER 目錄 B58-62. 尺寸, mm

### 粗搪刀頭 SW, 319 系列, Ø 20 - 66 mm

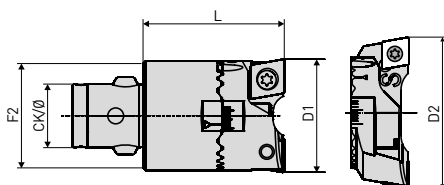

搪刀頭	CK/Ø	D1	D2	L	F2
SW 20	CKB1/11	20-26	25-31	32.5	19
SW 25	CKB2/14	25-33	32-40	35.5	24
SW 32	CKB3/18	32-42	41-51	40	31
SW 41	CKB4/22	41-54	50-63	47	39

請參閱 BIG KAISER 目錄 B27-31. 尺寸, mm

## 刀把粗胚

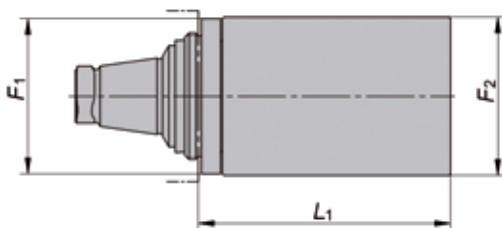

尺寸	訂購編號	F <sub>1</sub>	F <sub>2</sub>	L <sub>1</sub>
ER-20QF	329020000	36	35	60
ER-25QF	329025000	49	50	80
ER-32QF	329032000	58	60	80
ER-40QF	329040000	71	70	100
ER-50QF	329050000	82	80	100

尺寸, mm

## 保護蓋

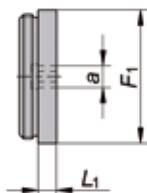

尺寸	訂購編號	F <sub>1</sub>	L <sub>1</sub>	a
ER-20QF	337020000	33	6	6
ER-25QF	337025000	43	6	6
ER-32QF	337032000	52	10	8
ER-40QF	337040000	66	10	10
ER-50QF	337050000	76	10	12

尺寸, mm

## 7/24斜錐刀把

DIN ISO 69871, 刀具設定儀用

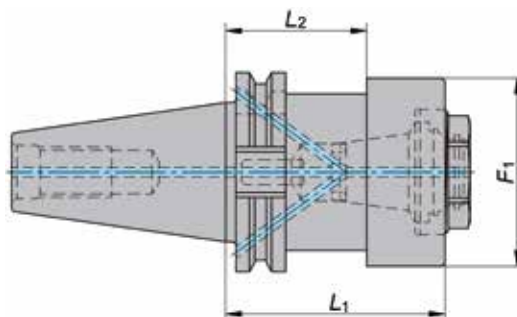



尺寸	訂購編號	SK	F <sub>1</sub>	L <sub>1</sub>	L <sub>2</sub>	
ER-20QF	338120040	SK40	50	40	-	107520020
	338120050	SK50	50	40	-	107520020
ER-25QF	338125040	SK40	50	40	-	107525020
	338125050	SK50	50	40	-	107525020
ER-32QF	338132040	SK40	63	60	35	107532020
	338132050	SK50	63	60	-	107532020
ER-40QF	338140050	SK50	78	60	-	107540020
ER-50QF	338150050	SK50	85	60	35	107550020

尺寸, mm

## HSK 刀把

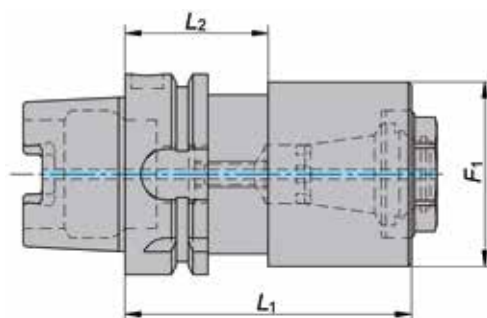
DIN 69893A/C (ISO 12164A/C), 刀具設定儀用



尺寸	訂購編號	HSK	F <sub>1</sub>	L <sub>1</sub>	L <sub>2</sub>	
ER-20QF	338120063	HSK63A	50	85	-	107520020
ER-25QF	338125063	HSK63A	50	90	-	107525020
ER-32QF	338132063	HSK63A	63	90	42	107532020
ER-40QF	338140063	HSK63A	78	100	42	107540020
ER-50QF	338150063	HSK63A	85	120	42	107550020

尺寸, mm

## 刀具量測預校刀把

刻有標準量測尺寸

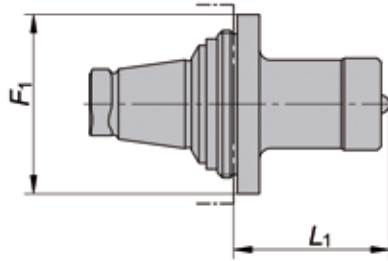

尺寸	訂購編號	F1	L1
ER-20QF	339020000	36	42.25
ER-25QF	339025000	49	42.25
ER-32QF	339032000	58	45.25
ER-40QF	339040000	71	43.25
ER-50QF	339050000	82	45.25

尺寸, mm

## 測試棒

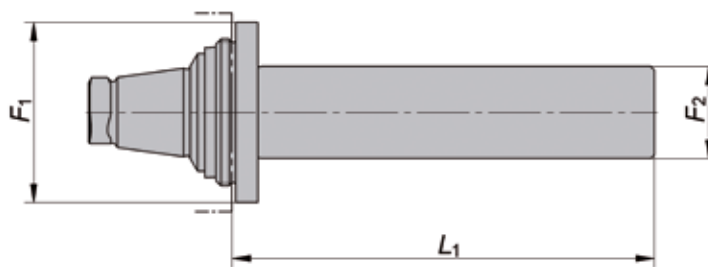

尺寸	訂購編號	F1	F2	L1
ER-20QF	339120000	36	20	85
ER-25QF	339125000	49	25	115
ER-32QF	339132000	58	32	115
ER-40QF	339140000	71	32	115
ER-50QF	339150000	82	32	115

尺寸, mm. 木盒包裝

## QuickFlex® 刀具安裝設備

QuickFlex® 簡易型刀具更換夾具, 可固定於工作臺上

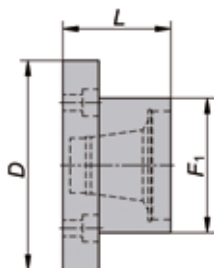

尺寸	訂購編號	F1	L	D	
ER-20QF	338220000	45	45	87	107520020
ER-25QF	338225000	55	45	97	107525020
ER-32QF	338232000	65	60	107	107532020
ER-40QF	338240000	75	60	117	107540020
ER-50QF	338250000	86	80	127	107550020

尺寸, mm

## “Toolboy” 刀具更換夾具 (PWB系統)

可固定於工作臺上, 輕鬆的更換QuickFlex® 刀柄, 可調整角度



## QuickFlex® 刀具更換模組座

配合下列夾座, 可在“Toolboy”刀具更換夾具上使用

- WTO 338200001
- PWB 系統 400141-8 (C8)



尺寸	訂購編號	
ER-20QF	338220010	107520020
ER-25QF	338225010	107525020
ER-32QF	338232010	107532020
ER-40QF	338240010	107540020
ER-50QF	338250010	107550020

## 夾座

配合本體使用

- WTO 338200000
- PWB 系統 400500



訂購編號 夾座  
338200001

## 本體



訂購編號 本體  
338200000

## 快換刀把收納架

配合 QuickFlex® 快換刀把 (18 支)



尺寸 | 訂購編號

ER-20QF | 338320000

ER-25QF | 338325000

ER-32QF | 338332000

ER-40QF | 338340000

WxHxD: 600x272x262 mm



## QuickFlex® 刀把螺絲環

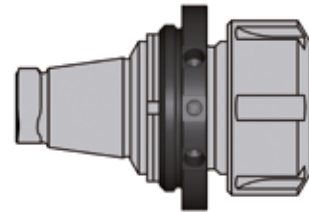
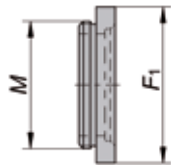

尺寸	訂購編號	M	F <sub>1</sub>
ER-20QF	337120000	M 32 x 1.50	36
ER-25QF	337125000	M 40 x 1.50	49
ER-32QF	337132000	M 50 x 1.50	58
ER-40QF	337140000	M 62 x 1.50	71
ER-50QF	337150000	M 68 x 1.50	82

尺寸, mm

## QuickFlex® 刀把螺絲環鎖固墊片

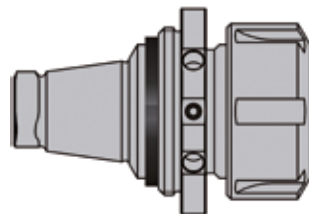



尺寸	訂購編號
ER-20QF	337220000
ER-25QF	337225000
ER-32QF	337232000
ER-40QF	337240000
ER-50QF	337250000

## ERQF 筒夾鎖緊螺帽

中心出水時，需加裝密封墊片

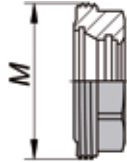
DIN 6499, ISO 15488



尺寸	訂購編號	M	Nm	密封墊片	
ER-20QF	207020000	M 32 x 1.50	80	210120...	107520020
ER-25QF	207025000	M 40 x 1.50	110	210125...	107525020
ER-32QF	207032000	M 50 x 1.50	140	210132...	107532020

請注意最大鎖緊扭力 (Nm)! 尺寸, mm

## ERQF-BC 筒夾鎖緊螺帽

內附滾珠軸承。中心出水時，需加裝密封墊片

DIN 6499, ISO 15488

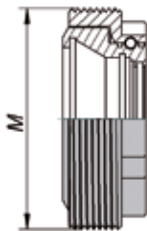

尺寸	訂購編號	M	Nm	密封墊片	
ER-40QF	208040001	M 62 x 1.50	180	210140...	107540020
ER-50QF	208050001	M 68 x 1.50	240	210150...	107550020

請注意最大鎖緊扭力 (Nm)! 尺寸, mm



## ERQF-A 筒夾鎖緊螺帽 - 短型

外冷

DIN 6499B, ISO 15488

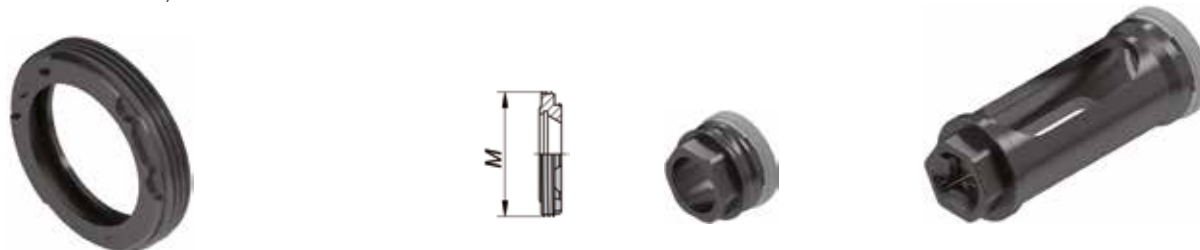

尺寸	訂購編號	M	Nm						
ER-20QF	202120001	M 32 x 1.50	75	107525101	107525104	27	107525102	22	1/2"
ER-25QF	202125001	M 40 x 1.50	90	107532101	107532104	30	107532102	27	1/2"
ER-32QF	202132001	M 50 x 1.50	130	107540101	107540104	36	107540102	27	1/2"
ER-40QF	202140001	M 62 x 1.50	150	107540101	107540104	36	107540102	27	1/2"

請注意最大鎖緊扭力 (Nm)! 尺寸, mm

## 筒夾鎖緊螺帽密封墊片

中心出水中心出水用



訂購例:  
210116040 配合 ER 16 及刀柄  
d = 4.0 - 3.5

尺寸	訂購編號, 單一密封墊片	訂購編號, 整組密封墊片	d min.	d max.	單一密封墊片 使用範圍	整組密封墊 片數量	整組密封墊片使用範圍
ER 16	210116...[d*10]	210116000	3.0	10	0.5	14	3.0-10
ER 20	210120...[d*10]	210120000	3.0	13	0.5	20	3.0-13
ER 25	210125...[d*10]	210125000	3.0	16	0.5	26	3.0-16
ER 32	210132...[d*10]	210132000	3.0	20	0.5	34	3.0-20
ER 40	210140...[d*10]	210140000	3.0	26	0.5	46	3.0-26

尺寸, mm

## 單手固定板手

裝卸刀具時，用來固定QuickFlex® 主軸



尺寸	訂購編號
20	107720000
25	107725000
32	107732000
40	107740000
50	107750000

## 板手

裝卸刀具時，用來鎖緊或鬆開ERQF 筒夾鎖緊螺帽及QuickFlex® 快換刀把



**A**



**B**

尺寸	訂購編號	型式
ER-20QF	107520020	A
ER-25QF	107525020	A
ER-32QF	107532020	A
ER-40QF	107540020	B
ER-50QF	107550020	B

## 可換頭扭力扳手

適用於下列扭力扳手頭



尺寸	訂購編號	Ø	Nm
ER-20QF 到 ER-25QF	STW-D16-100-A	16	20 - 100
ER-32QF 到 ER-50QF	STW-D16-200-A	16	40 - 200

尺寸, mm

## 扭力扳手頭

QuickFlex® 快換刀把用



尺寸	訂購編號	Nm <sup>1)</sup>
ER-20QF	107520021	65
ER-25QF	107525021	80
ER-32QF	107532021	100
ER-40QF	107540021	140
ER-50QF	107550021	160

用于套管端 Ø16

ERQF 標準螺帽用



A



B

尺寸	訂購編號		Nm <sup>1)</sup>
ER-20QF	107520022	A	75
ER-25QF	107525022	A	100
ER-32QF	107532022	A	130
ER-40QF	107540022	B	165
ER-50QF	107550022	B	200

用于套管端 Ø16

ERQF-A 短螺帽用



尺寸	訂購編號	Nm <sup>1)</sup>
ER-25QF	107532105	85
ER-32QF	107540105	130
ER-40QF	107540105	130

用于套管端 Ø16

<sup>1)</sup> 使用扭矩扳手 STW-D16-... 时要设置扭矩

# 高精度ER筒夹

DIN 6499B, ISO 15488

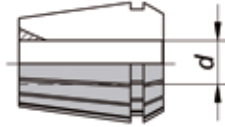

d	ER-11	ER-16	ER-20	ER-25	ER-32	ER-40	ER-50
1-0.5	190011010	190016010	190020010	190025010			
1.5-1	190011015						
2-1.5	190011020	190016020	190020020	190025020	190032020		
2.5-2	190011025						
3-2.5	190011030	190016030	190020030	190025030	190032030	190040030	
3.5-3	190011035						
4-3.5	190011040	190016040	190020040	190025040	190032040	190040040	
4.5-4	190011045						
5-4.5	190011050	190016050	190020050	190025050	190032050	190040050	
5.5-5	190011055						190050060
6-5.5	190011060	190016060	190020060	190025060	190032060	190040060	
6.5-6	190011065						
7-6.5	190011070	190016070	190020070	190025070	190032070	190040070	190050080
8-7		190016080	190020080	190025080	190032080	190040080	
9-8		190016090	190020090	190025090	190032090	190040090	
10-9		190016100	190020100	190025100	190032100	190040100	190050100
11-10			190020110	190025110	190032110	190040110	
12-11			190020120	190025120	190032120	190040120	190050120
13-12			190020130	190025130	190032130	190040130	
14-13				190025140	190032140	190040140	190050140
15-14				190025150	190032150	190040150	190050160
16-15				190025160	190032160	190040160	
17-16					190032170	190040170	
18-17					190032180	190040180	190050180
19-18					190032190	190040190	
20-19					190032200	190040200	190050200
21-20						190040210	
22-21						190040220	190050220
23-22						190040230	
24-23						190040240	190050240
25-24						190040250	
26-25						190040260	190050260
28-26							190050280
30-28							190050300
32-30							190050320
34-32							190050340

尺寸為  
mm

尺寸, mm. 偏擺 max. 0.01 mm

整套 d	ER-11	ER-16	ER-20	ER-25	ER-32	ER-40	ER-50
7-0.5	190011000						
10-0.5		190016000					
13-1			190020000				
16-1				190025000			
20-2					190032000		
26-3						190040000	
34-10							190050000
數量	13	10	12	15	18	23	12

尺寸, mm. 偏擺 max. 0.01 mm



## 超高精度ER筒夾

DIN 6499B, ISO 15488

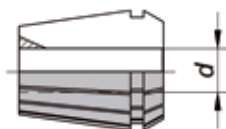

d	ER-11	ER-16	ER-20	ER-25	ER-32	ER-40	ER-50
1-0.5	190111010	190116010	190120010	190125010			
1.5-1	190111015						
2-1.5	190111020	190116020	190120020	190125020	190132020		
2.5-2	190111025						
3-2.5	190111030	190116030	190120030	190125030	190132030	190140030	
3.5-3	190111035						
4-3.5	190111040	190116040	190120040	190125040	190132040	190140040	
4.5-4	190111045						
5-4.5	190111050	190116050	190120050	190125050	190132050	190140050	
5.5-5	190111055						190150060
6-5.5	190111060	190116060	190120060	190125060	190132060	190140060	
6.5-6	190111065						
7-6.5	190111070	190116070	190120070	190125070	190132070	190140070	190150080
8-7		190116080	190120080	190125080	190132080	190140080	
9-8		190116090	190120090	190125090	190132090	190140090	
10-9		190116100	190120100	190125100	190132100	190140100	190150100
11-10			190120110	190125110	190132110	190140110	
12-11			190120120	190125120	190132120	190140120	190150120
13-12			190120130	190125130	190132130	190140130	
14-13				190125140	190132140	190140140	190150140
15-14				190125150	190132150	190140150	
16-15				190125160	190132160	190140160	190150160
17-16					190132170	190140170	
18-17					190132180	190140180	190150180
19-18					190132190	190140190	
20-19					190132200	190140200	190150200
21-20						190140210	
22-21						190140220	190150220
23-22						190140230	
24-23						190140240	190150240
25-24						190140250	
26-25						190140260	190150260
28-26							190150280
30-28							190150300
32-30							190150320
34-32							190150340

尺寸, mm. 偏擺 max. 0.005 mm

整套 d	ER-11	ER-16	ER-20	ER-25	ER-32	ER-40	ER-50
7-0.5	190111000						
10-0.5		190116000					
13-1			190120000				
16-1				190125000			
20-2					190132000		
26-3						190140000	
34-10							190150000
數量	13	10	12	15	18	23	12

尺寸, mm. 偏擺 max. 0.005 mm

尺寸為  
mm

## ER筒夾, 高精度

中心出水用密封筒夾 (最高壓力 1740 PSI/120 bar)

DIN 6499A, ISO 15488

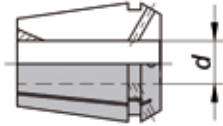

d	ER-11	ER-16	ER-20	ER-25	ER-32	ER-40
3	191011030	191016030	191020030	191025030	191032030	
4	191011040	191016040	191020040	191025040	191032040	
5	191011050	191016050	191020050	191025050	191032050	
6	191011060	191016060	191020060	191025060	191032060	191040060
7		191016070	191020070	191025070	191032070	
8		191016080	191020080	191025080	191032080	191040080
9		191016090	191020090	191025090	191032090	
10		191016100	191020100	191025100	191032100	191040100
11			191020110	191025110	191032110	
12			191020120	191025120	191032120	191040120
13				191025130	191032130	
14				191025140	191032140	191040140
15				191025150	191032150	
16				191025160	191032160	191040160
17					191032170	
18					191032180	191040180
19					191032190	
20					191032200	191040200
22						191040220
25						191040250

配合公差h8刀柄

尺寸, mm. 偏擺 max. 0.01 mm

整組 mm	ER-16	ER-20	ER-25	ER-32
10, 8, 6, 5, 4, 3	191016000			
12, 10, 8, 6, 5, 4, 3		191020000		
16, 14, 12, 10, 8, 6, 4			191025000	
20, 16, 14, 12, 10, 8, 6, 4				191032000
數量	6	7	7	8

尺寸, mm. 偏擺 max. 0.01 mm



## TER熱縮用筒夾

可供中心出水用, (最高壓力1740 PSI/120 bar)

DIN 6499, ISO 15488

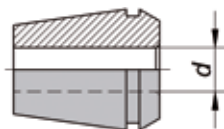

d	ER-11	ER-16	ER-20	ER-25	ER-32
3	192011030	192016030	192020030	192025030	
4	192011040	192016040	192020040	192025040	
6	192011060	192016060	192020060	192025060	192032060
8		192016080	192020080	192025080	192032080
10			192020100 <sup>1)</sup>	192025100	192032100
12				192025120	192032120
14				192025140 <sup>1)</sup>	192032140
16				192025160 <sup>1)</sup>	192032160
18					192032180 <sup>1)</sup>
20					192032200 <sup>1)</sup>

尺寸, mm. 偏擺 max. 0.003 mm

尺寸為  
mm

配合公差h6刀柄

<sup>1)</sup> 配合短螺帽 ERQF-A使用:



注意:

為確保熱縮夾持力, 裝入刀具前, 請維持刀柄乾淨, 無污垢或黏附切屑.

## 熱縮機

TER熱縮用筒夾推薦配合ThermoGrip® 熱縮機.

詳情請洽[www.diebold-hsk.de](http://www.diebold-hsk.de) 或 [www.bilz.com](http://www.bilz.com).

## ER-GB 攻牙筒夾

剛性攻牙用

DIN 6499A, ISO 15488

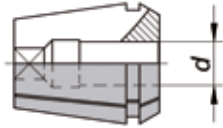

d ∅	d □	ER-11-GB	ER-16-GB	ER-20-GB	ER-25-GB	ER-32-GB	ER-40-GB	ER-50-GB
2.8	2.1	181011028	181016028					
3.5	2.7	181011035	181016035	181020035	181025035			
4	3.15/3.2	181011040	181016040	181020040	181025040	181032040		
4.5	3.4	181011045	181016045	181020045	181025045	181032045		
5	4	181011050	181016050	181020050	181025050	181032050		
5.5	4.3		181016055	181020055	181025055	181032055		
6	4.9	181011060	181016060	181020060	181025060	181032060	181040060	
6.2	5		181016062	181020062	181025062	181032062	181040062	
6.3	5		181016063	181020063	181025063	181032063	181040063	
7	5.5		181016070	181020070	181025070	181032070	181040070	
7.1	5.6		181016071	181020071	181025071	181032071	181040071	
8	6.2/6.3		181016080	181020080	181025080	181032080	181040080	
8.5	6.5		181016085	181020085	181025085	181032085	181040085	
9	7/7.1		181016090	181020090	181025090	181032090	181040090	
10	8			181020100	181025100	181032100	181040100	
10.5	8			181020105	181025105	181032105	181040105	
11	9			181020110	181025110	181032110	181040110	
11.2	9			181020112	181025112	181032112	181040112	
12	9			181020120	181025120	181032120	181040120	
12.5	10				181025125	181032125	181040125	
14	11/11.2				181025140	181032140	181040140	
15	12				181025150	181032150	181040150	
16	12/12.5				181025160	181032160	181040160	
17	13					181032170	181040170	
18	14/14.5					181032180	181040180	
20	16					181032200	181040200	
22	18						181040220	181050220
25	20						181040250	181050250
28	22							181050280
32	24							181050320

尺寸為  
mm

尺寸, mm. 偏擺 max. 0.01 mm







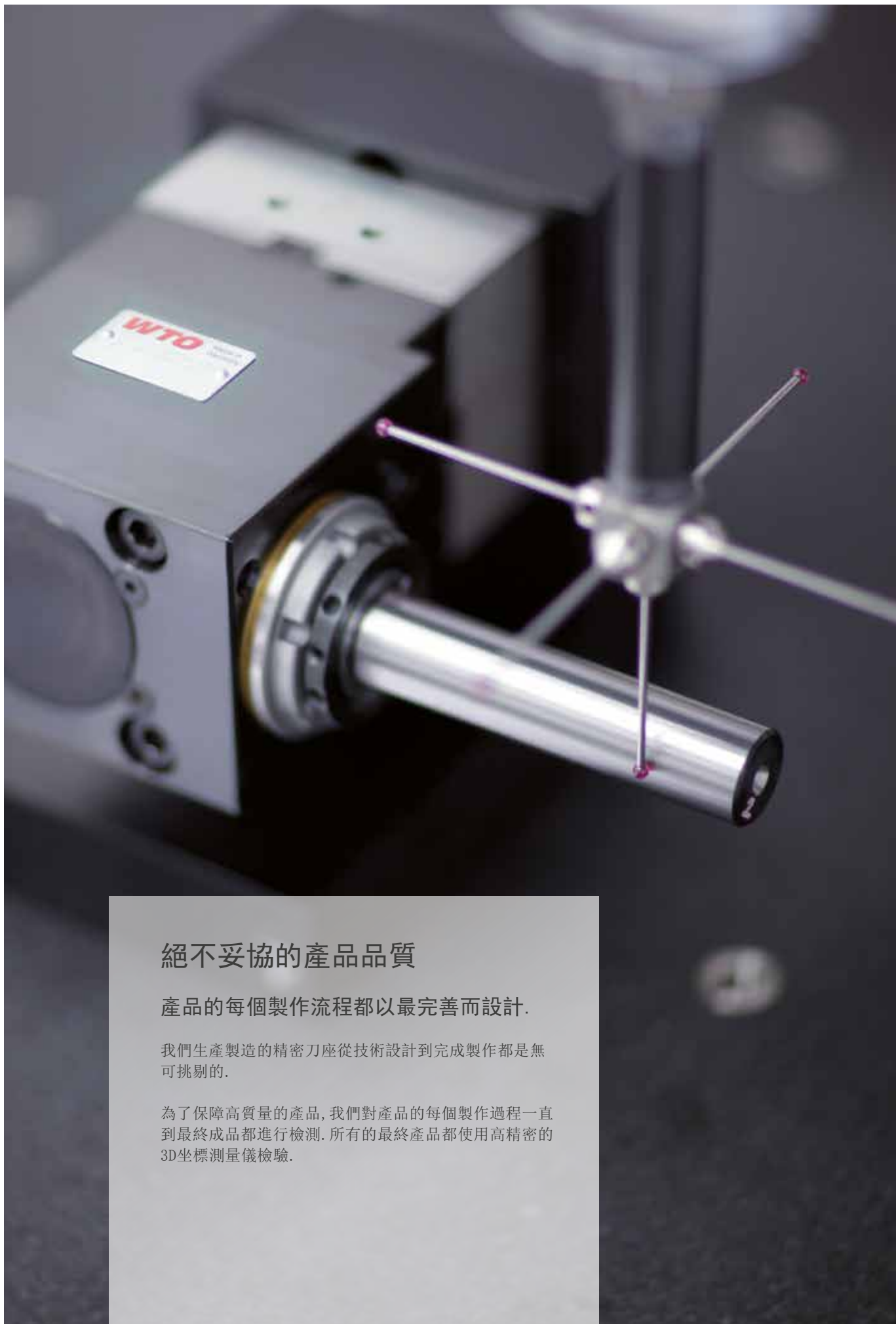

## 絕不妥協的產品品質

產品的每個製作流程都以最完善而設計。

我們生產製造的精密刀座從技術設計到完成製作都是無可挑剔的。

為了保障高質量的產品，我們對產品的每個製作過程一直到最終成品都進行檢測。所有的最終產品都使用高精密的3D坐標測量儀檢驗。

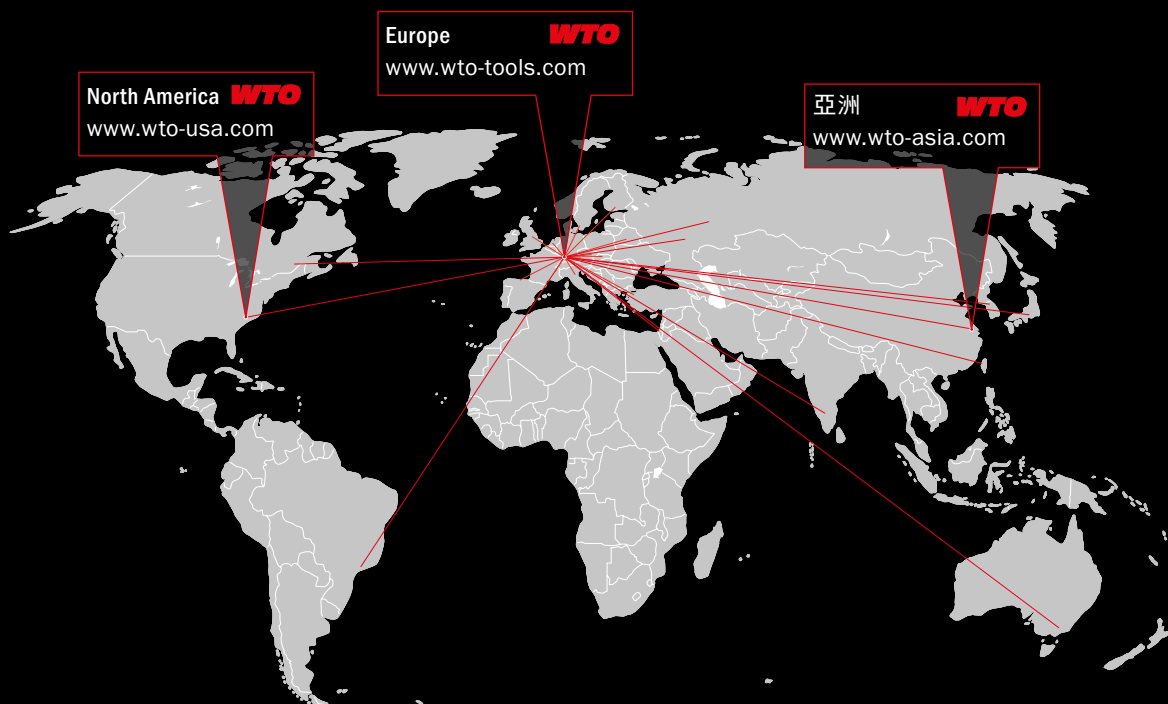

WTO  
Werkzeug-  
Einrichtungen GmbH 德國  
Neuer Hohdammweg 1  
77797 Ohlsbach  
德國

WTO Inc. 美國  
13900-F South Lakes Dr.  
Charlotte, NC 28273  
美國

WTO 亞洲  
WTO Precision Tool Holders  
(Shanghai) Co. Ltd.  
Room 109-110, Building 2  
No. 228 Banting Road  
Jiuting Town,  
Songjiang District  
201615 Shanghai  
中國

## 我們的全球合作夥伴。提供充分的技術及服務

澳大利亞  
Dimac Tooling Ltd.  
sales@dimac.com.au

英國  
Cutwel Ltd.  
sales@cutwel.net

墨西哥  
Workholding Engineering De México  
info@wem.com.mx

斯洛伐克  
ALBA precision s.r.o.  
albabprecision@albabprecision.sk

白俄羅斯  
LLC „PMI Engineering“  
tool@pmi.by

印度  
Ulhas Patil  
u.patil@wto-asia.com

荷蘭  
Toologic BeNeLux B.V.  
info@toologic-benelux.nl

西班牙  
ITALMATIC, S.A.  
italmatic@italmatic.es

巴西  
TF2  
tfdois@tfdois.com.br

以色列  
E.Y.A.R. Ltd.  
boris@eyar.co.il

挪威  
Helge Karlsen Verktøy og Maskin AS  
hkvm@hkvm.no

台灣  
Kaiko Co., Ltd.  
info@kaiko.com.tw

中國  
Shanghai Gangde  
wtocando@yahoo.com

意大利  
Prymark srl  
commerciale@prymark.it

波蘭  
ARCO Andrzej Rudenko  
info@arcotools.pl

土耳其  
MYK CNC MAKINA SAN. VE  
huseyin.tatlidil@mykcnc.com.tr

丹麥  
AVN Teknik A/S  
cjo@avn.dk

日本  
NK Works Co. Ltd.  
k\_samba@nk-works.co.jp

羅馬尼亞  
SC Elif Trading SRL  
bulent.ozkan@eliftrading.com

捷克  
ALBA precision, spol. s.r.o.  
info@albabprecision.cz

芬蘭  
Suomen Terätuonti Oy  
myynti@stt.as

加拿大  
Mittmann Industrial Inc.  
info@mittmann.com

瑞典  
Bonhron & Ewing AB  
info@bonhron-ewing.se

烏克蘭  
„LLC“ SPA Stankopromimport  
info@phoenix-ua.com

法國  
Alexandre Mathelin  
alm@wto.de

韓國  
WTO Office Korea  
is.chon@wto-korea.com

瑞士  
Utilis AG  
info@utilis.com